

MODEL

SSCT

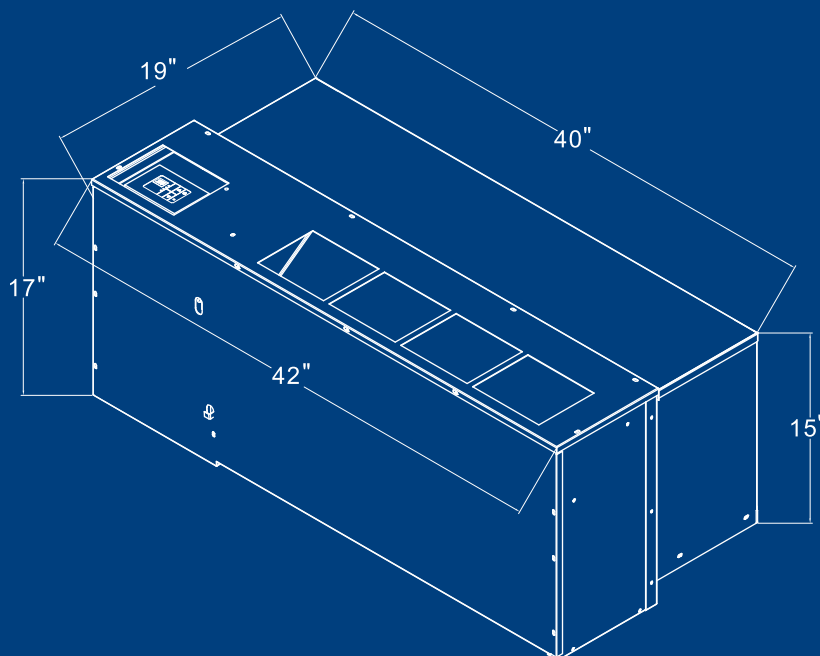

AN EXACT CHASSIS REPLACEMENT
FOR THE 40X15"
CONDENSER ICE-CAP RSCT,
ISLANDAIRE EZ SERIES RT AND NY





Line Voltage	Maximum Amperage	Wall Socket Configuration	Receptacle Number	Electrical Heat Options
115	16		NEMA5-20R	3.0-3.5
208/230	12		NEMA6-15R	3.0-3.5
208/230	16		NEMA6-20R	3.0-3.5
208/230	24		NEMA6-30R	3.0-3.5
270	16		NEMA7-20R	3.0-3.5

- ANALOG CONTROL AND MAIN THERMOSTAT (OPTIONAL)
PTC CERAMIC ELECTRIC HEAT OPTION AVAILABLE-CONSULT FACTORY

MODEL	SSCT513H-TP	SSCT816H-TP
FAN SPEED	HIGH/LOW	HIGH/LOW
COOLING CAPACITY (BTU/h)	13300	16000
HEATING CAPACITY HOT WATER (BTU/h)	16500/15100	16500/15100
VOLTAGE (V)	115V	208V
WATTS (W)	1330	1690
AIR FLOW (CFM)	310/270	390/300
AMPS (A)	11.8	8.8
EER	10.0	9.45
R410 CHARGE OZ.	39.8	38.8
CHASSIS DIMENSIONS (in.)	40 X 19 X 15	40 X 19 X 15
SHIPPING BOX DIMENSION (in.)	46 3/4 X 23 3/4 X 20 1/2	46 3/4 X 23 3/4 X 20 1/2
WEIGHT (LBS)	152	158
LOADING (40'20')	120/52	120/52
HEATING CAPACITY STM (BTU/h)	18700/16500	18700/16500

- Important Note: Due to the ongoing development, the performance, specifications, components, and design is subject to change without notice. Please contact factory.
All chassis are Tested and Rated in Accordance with ARI 310/380 and UL Standard 484.
All "replacement" PTAC chassis are UL Listed for safety and ETL tested.