

# MODEL SSZ

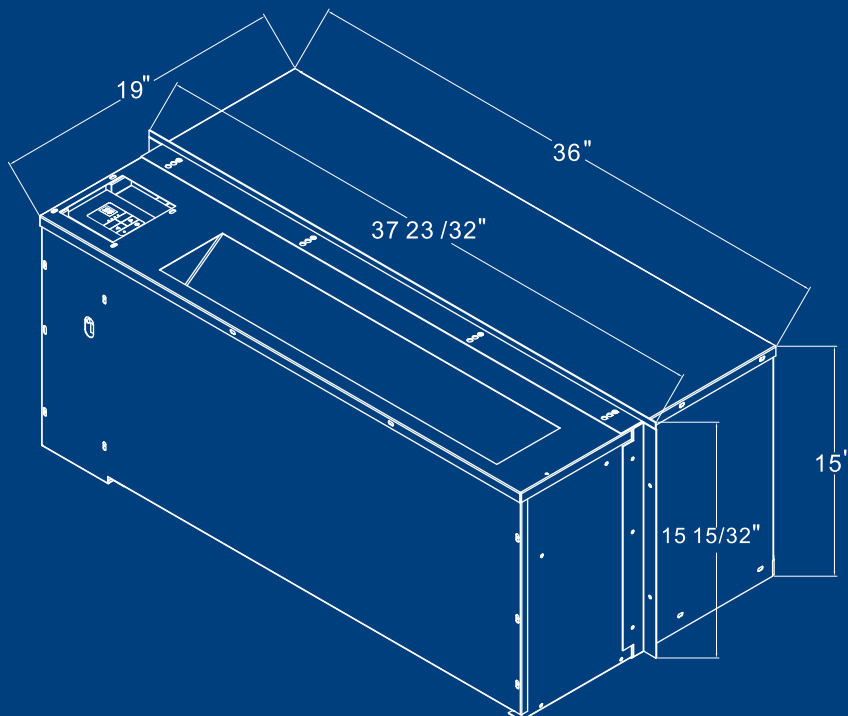

EXACT CHASSIS REPLACEMENT  
FOR THE:  
EMBASSY WEATHER TWIN  
KAPSIS COOL HEAT  
TPI RA-MATIC  
ZONEAIRE RM & SC SERIES  
ICECAP RSZ  
ISLANDAIRE EZ SERIES RM





Line Voltage	Maximum Amperage	Wall Socket Configuration	Receptacle Number	Electrical Heat Options
115	16		NEMA5-20R	3.0-3.5
208/230	12		NEMA6-15R	3.0-3.5
208/230	16		NEMA6-20R	3.0-3.5
208/230	24		NEMA6-30R	3.0-3.5
270	16		NEMA7-20R	3.0-3.5

- ANALOG CONTROL AND MAIN THERMOSTAT (OPTIONAL)  
PTC CERAMIC ELECTRIC HEAT OPTION AVAILABLE-CONSULT FACTORY

MODEL	SSZ509H-TP	SSZ809H-TP	SSZ513H-TP	SSZ813H-TP	SSZ818H-TP
FAN SPEED	HIGH/LOW	HIGH/LOW	HIGH/LOW	HIGH/LOW	HIGH/LOW
COOLING CAPACITY (BTU/h)	9200	8700	11400	12200	16400
HEATING CAPACITY HOT WATER (BTU/h)	16500/15100	16500/15100	16500/15100	16500/15100	16500/15100
VOLTAGE (V)	115V	208V	115V	208V	208V
WATTS (W)	976	963	1307	1427	2052
AIR FLOW (CFM)	375/290	450/300	390/320	450/300	450/300
AMPS (A)	8.7	4.6	11.6	6.9	9.9
EER	9.43	9.03	8.72	8.55	8.0
R410 CHARGE OZ.	25.4	26.5	28.2	28.2	38.8
CHASSIS DIMENSIONS (in.)	36 X 19 X 15	36 X 19 X 15	36 X 19 X 15	36 X 19 X 15	36 X 19 X 15
SHIPPING BOX DIMENSION (in.)	40 3/4 X 23 3/4 X 18 1/2	40 3/4 X 23 3/4 X 18 1/2	40 3/4 X 23 3/4 X 18 1/2	40 3/4 X 23 3/4 X 18 1/2	40 3/4 X 23 3/4 X 18 1/2
WEIGHT (LBS)	134	134	138	152	152
LOADING (40'20')	160/72	160/72	160/72	160/72	160/72
HEATING CAPACITY STM (BTU/h)	18700/16500	18700/16500	18700/16500	18700/16500	20000/19400

- Important Note: Due to the ongoing development, the performance, specifications, components, and design is subject to change without notice. Please contact factory.  
All chassis are Tested and Rated in Accordance with ARI 310/380 and UL Standard 484.  
All "replacement" PTAC chassis are UL Listed for safety and ETL tested.