

MODEL

SS45

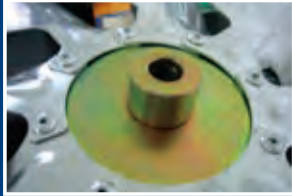

EXACT REPLACEMENT FOR THE
AMERICAN STANDARD CARTERET45
REMINGTON45
SINGER 45

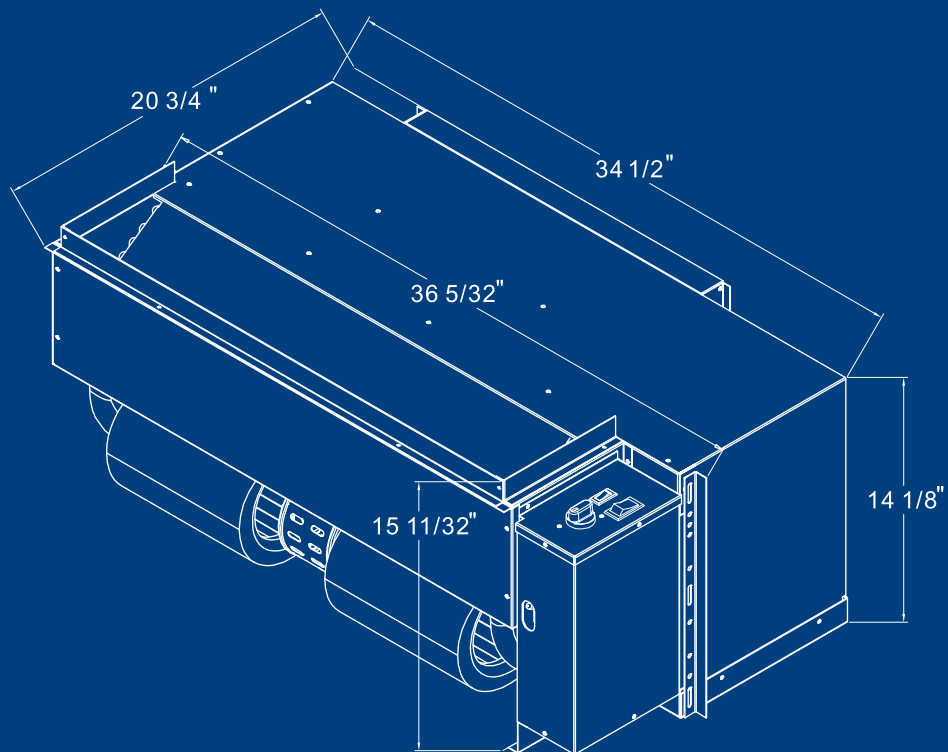

SIMON-AIRE INC.

SS45



410A
REFRIGERANT



Line Voltage	Maximum Amperage	Wall Socket Configuration	Receptacle Number	Electrical Heat Options
115	16	⊕	NEMA5-20R	3.0-3.5
208/230	12	⊖	NEMA6-15R	3.0-3.5
208/230	16	⊕	NEMA6-20R	3.0-3.5
208/230	24	⊖	NEMA6-30R	3.0-3.5
270	16	⊙	NEMA7-20R	3.0-3.5

- ANALOG CONTROL AND MAIN THERMOSTAT (OPTIONAL)
PTC CERAMIC ELECTRIC HEAT OPTION AVAILABLE-CONSULT FACTORY

MODEL	SS45509H	SS45809H	SS45513H	SS45813H	SS45818H
FAN SPEED	HIGH/LOW	HIGH/LOW	HIGH/LOW	HIGH/LOW	HIGH/LOW
COOLING CAPACITY (BTU/h)	9200	8700	11400	12200	16400
HEATING CAPACITY HOT WATER (BTU/h)	16500/15100	16500/15100	16500/15100	16500/15100	19400/18100
VOLTAGE (V)	115V	208V	115V	208V	208V
WATTS (W)	976	963	1307	1427	2052
AIR FLOW (CFM)	375/290	480/330	375/290	470/320	480/335
AMPS (A)	8.7	4.6	11.6	6.9	9.9
EER	9.43	9.03	8.72	8.55	8.0
R410 CHARGE OZ.	25.4	26.5	30	30	42.3
CHASSIS DIMENSIONS (in.)	34 1/2 X 20 3/4 X 14 1/8	34 1/2 X 20 3/4 X 14 1/8	34 1/2 X 20 3/4 X 14 1/8	34 1/2 X 20 3/4 X 14 1/8	34 1/2 X 20 3/4 X 14 1/8
SHIPPING BOX DIMENSION (in.)	39 1/2 X 24 1/4 X 19 3/4	39 1/2 X 24 1/4 X 19 3/4	39 1/2 X 24 1/4 X 19 3/4	39 1/2 X 24 1/4 X 19 3/4	39 1/2 X 24 1/4 X 19 3/4
WEIGHT (LBS)	125	125	136	136	152
LOADING (40'20')	160/72	160/72	160/72	160/72	160/72
HEATING CAPACITY STM (BTU/h)	18700/16500	18700/16500	18700/16500	18700/16500	20000/19400

- Important Note: Due to the ongoing development, the performance, specifications, components, and design is subject to change without notice. Please contact factory.
All chassis are Tested and Rated in Accordance with ARI 310/380 and UL Standard 484.
All "replacement" PTAC chassis are UL Listed for safety and ETL tested.